



Operators Manual

MANLINK-4D REV H 12/11/20 400L / 600L / 800 / 1100L Super Series Linkage Sprayer



Introduction



Silvan is an Australian owned company specialising in supply of crop protection equipment to primary producers. A leader in the design of agricultural sprayers, the company was established in 1962 and has grown to become the largest manufacturer and supplier of crop protection equipment in Australia.

Silvan's reputation for quality products backed by quality service is something of which we are extremely proud. Your investment in a Silvan sprayer is an investment in quality.

This manual covers the 400L, 600L, 800L and 1100L Super Series linkage sprayers, which have been designed and manufactured to provide a high standard of performance and safety and incorporate many innovative features. To ensure continued efficient performance and safe operation of your sprayer, you need to read this manual thoroughly and fully familiarise yourself with all aspects of the sprayers operation, maintenance and safety procedures.

Now that you are a proud Silvan owner, all our services and dealer support is available to you should you need them. We assure you of our best attention at all times.

No liability can be accepted for any inaccuracies or omissions in this publication, although due care has been taken to make it as complete and accurate as possible.

The information, illustrations and technical data were considered to be correct at the time of preparation.

In accordance with our policy of continuous development, Silvan Australia Pty. Ltd. reserves the right to make changes at any time without notice.

Contents



Introduction	2
Contents	3
Sprayer details	3
Warranty	4
Safety Information	5
Decals Position & Description	6
Specifications	7-8
Operation	9-13
Attaching to the tractor, PTO Shaft, Pump	9
Optional Flush Tank	10
Filter, Control Units, Lower Links & Boom Attachment	11
Fresh water Tank, Toolbox, Spray Booms	11
Spray Guns, Hose Reels and Foam Marker	12
Starting the sprayer	13
Chemical induction probe (1100L only)	13
Shutdown	13
General Spraying Information	
When to spray, field patterns, droplet size.	14
Nozzle height, application rate, ground speed	14
Calibration	
Testing, verifying calibration, nozzle maintenance	15
Nozzle selection	16
Using Nozzle Calibration Charts	16
Maintenance	17-18
Trouble Shooting	19

YOUR SPRAYER DETAILS

Record the details of your sprayer here for future reference when discussing service with your Silvan dealer, ordering parts or making a warranty claim.

SERIAL NUMBER _____

MODEL _____

DATE OF DELIVERY _____

SELLING DEALER _____

ADDRESS _____

TELEPHONE NO. _____

INSTALLED BY _____

Warranty



Silvan Australia Pty. Ltd. builds equipment to a high level of specification using components from quality suppliers. The following information is provided to assist you with any repairs required within the warranty period. All warranty repairs on Silvan products are carried out by Silvan dealers. If any warranty repairs are required on Silvan products, it is recommended that the product be returned to the place of purchase. It is good practice to keep a record of equipment maintenance both during and after the warranty period.

The warranty policy below explains the extent and limitations of your Warranty coverage on Silvan Products.

Our goods come with guarantees that cannot be excluded under the Australian Consumer Law. You are entitled to a replacement or refund for a major failure and for compensation for any other reasonably foreseeable loss or damage. You are also entitled to have the goods repaired or replaced if the goods fail to be of acceptable quality and the failure does not amount to a major failure.

We warrant our goods to be free from defects in materials and workmanship for the warranty period of 12 months from the date the product is delivered to the consumer.

Silvan warrants its authorised Dealer, who in turn warrants the original purchaser (consumer) of each new Silvan product that it will repair or replace the product, or, pay the cost of repair or replacement, as determined by Silvan without charge for labour or any defective or malfunctioning parts in accordance with the warranty limitations below.

This Warranty is in addition to any other rights and remedies available to consumers under the law.

This Warranty Covers

Only conditions resulting directly from defects in workmanship or material under normal use and service.

Warranty Exclusions

The Warranty does not cover:

- Conditions resulting from misuse, use of incompatible chemicals, exceeding machine specifications including overloading, impact damage, negligence, accidental damage or failure to perform recommended maintenance services as specified in the Owner/Operator Manual applicable to the product.
- Damage caused by continued use of a product after initial failure
- Any product which has been repaired by other than an authorised Silvan service outlet in a way which, in the sole and absolute judgment of Silvan, adversely affect its performance or reliability.
- The replacement of maintenance items such as diaphragms, batteries, V belts and ground engaging components, etc.

How to claim Warranty

Return the goods to the place of purchase at your cost and within the warranty period along with evidence of the purchase date. If the original supplier cannot be contacted then contact Silvan as below and we can direct you on how to proceed with your warranty claim.

How your claim will be managed

The repair of a defective product qualifying under this warranty will be performed by any authorised Silvan service outlet within a reasonable time following the delivery of the product, at the cost of the owner, to the service outlet's place of business. The product will be repaired or replaced depending on the extent of the problem at the discretion of Silvan and the Silvan dealer.

Silvan Australia Pty Ltd
68 Atlantic Drive,
Keysborough,
Victoria 3173
1300 SILVAN (745 826)
support@silvanaust.com



Before operating the sprayer, read the following safety instructions.

Failure to comply with these warnings may result in serious injury or death.

- This sprayer is designed and manufactured solely for the purpose of applying agricultural chemicals to crops. Under no circumstances should it be used for any other purpose.
- Before using the sprayer, carefully read and ensure you understand the contents of this manual and any other manual supplied with the sprayer.
- Before operating the sprayer, read all the safety warnings, which are carried on various parts of the machine. Refer to the next page for a location diagram and the wording of these warnings.
- Never allow an inadequately trained person to attach or operate the sprayer.
- Do not operate the sprayer whilst wearing loose clothing, unrestrained long hair, jewellery or anything which could become entangled in rotating components or limit your vision.
- Wear ear protection when operating the sprayer on a tractor which is not fitted with a sound proofed cabin.
- Ensure the linkage capacity of the tractor is suitable for the loaded mass of the sprayer. Refer to the tractor operator's manual for safe working loads and relevant tractor safety instructions.
- Exercise extreme care when operating in hilly or uneven terrain to ensure adequate stability. Refer also to the tractor manufacturer's operating and safety instructions.
- Do not operate the pump at speeds greater than 540 PTO rpm and less than 400rpm.
- Do not operate the sprayer without all of the tractor and sprayer safety shields in place. Carefully check that PTO and driveline shields are correctly installed.
- Stop the tractor PTO, apply the parking brake and switch off the tractor engine before approaching the sprayer and performing any work on it.
- Disconnect the PTO shaft at the tractor and ensure the sprayer is properly supported before performing any maintenance work.
- **Before use of any chemicals** refer to the chemical manufacturer's label and safety instructions for safe handling procedures and correct method of use. Always use the recommended personal protective clothing and equipment.
- Always wear gloves when removing and cleaning filters.
- Dispose of empty chemical containers in accordance with the instructions supplied by the chemical manufacturer.
- Ensure that all operators and associated personnel are familiar with the legal regulations and codes of practice that apply to the safe use and storage of spray chemicals.
- Ensure chemicals are kept away from the fresh water tank. **Never drink water from the fresh water tank.**
- Ensure all bystanders are at a safe distance from the machine.
- Do not use flammable liquids or gases in the sprayer.

Decal Positions

 The location and wording of the safety decals fitted to Silvan linkage sprayers is shown below. It is important that all operators read and follow the information on all safety decals before operating the sprayer. **Failure to comply with these warnings could result in serious injury or death.** Safety decals should be kept clean and legible at all times. If any decals are missing or unreadable they should be replaced by ordering new decals from your Silvan dealer using the part numbers shown below.



DEC232



DEC52

CARE FORMING IMPLEMENT P.T.O SHAFT TO SUIT YOUR TRACTOR

NOTE: End thread from new length shafts (or second fabrication batch) can destroy your tractor's internal P.T.O drive or implement clutch and gearbox, voiding your tractor's internal P.T.O warranty.

- 1) Measure groove to groove (G-to-G) from implement shaft to tractor shaft with implement in straight position.
NOTE: Length will vary on implement to mount or beam.
- 2) Remove safety guard from new shaft and measure length between shaft lock buttons or clamp bolts with shaft in closed position.
- 3) Required length of shaft is groove to groove length (G-to-G) less a minimum of 10mm (1/2") to allow for disconnection from tractor and prevent end thrust damage of shafts to drive from the tractor. Add 50% of telescopic tubes over this.
- 4) Assemble to cut off shaft length of new shaft (step 2), using rollers to ground measure. Mark G-to-G on shaft (step 3) and the correct of both new and older shaft tubes. Remove burrs and sharp edges.
E.g. New shaft 2100mm (6'7") 2100mm (6'7") 2100mm (6'7") 2100mm (6'7")
Old shaft 2000mm (6'7") 2000mm (6'7") 2000mm (6'7") 2000mm (6'7")
Add 50% telescopic tubes over this.

INS142 INSTRUCTION BOOKLET

! WARNING

BEFORE APPLYING CHEMICALS WITH THIS SPRAYER READ THE LABEL OF THE CHEMICAL MANUFACTURER OR SUPPLIER FOR THE RECOMMENDED PERSONAL PROTECTIVE EQUIPMENT AND USE IT AS RECOMMENDED.

READ THE OPERATORS INSTRUCTION MANUAL BEFORE ATTACHING OR USING THIS PRODUCT.

REFER TO YOUR VEHICLE'S OPERATION MANUAL FOR THE MAXIMUM LOAD LIMITS AND OPERATING PROCEDURES.

DO NOT EXCEED SPECIFIED SAFE LOAD CARRY AND TOWING CAPACITIES. STABILITY OF THE VEHICLE CAN BE AFFECTED BY THE ATTACHMENT'S WEIGHT AND WEIGHT MOVEMENT.

REDUCE THE SPEED OF THE VEHICLE WHEN CARRYING AN ATTACHMENT AND ALLOW GREATER DISTANCE FOR BREAKING. DO NOT RIDE ON THIS MACHINE.

DANGER

DISCONNECT TRACTOR BEFORE ADJUSTING, SERVICING, CLEANING OR INSPECTING SPRAYER.

KEEP CLEAR OF OPERATING MACHINERY.

DO NOT OPERATE WITHOUT GUARDS OR SHIELD IN PLACE. FAILURE TO HEED THESE WARNINGS COULD RESULT IN SEVERE PERSONAL INJURY OR DEATH.

! IMPORTANT

P.T.O SPEED MUST NOT EXCEED 540 R.P.M & ENSURE P.T.O SHAFT IS CORRECT LENGTH.

EACH DAY: GREASE TELESCOPIC TUBE ON P.T.O SHAFT, GREASE UNIVERSAL JOINTS, CLEAN SUCTION STRAINER, CHECK PUMP OIL LEVEL, FLUSH OUT PUMP WITH WATER AFTER USE. FOR GENERAL MAINTENANCE, REFER TO THE INSTRUCTION MANUAL.

DEC 101213P

! DANGER



ROTATING DRIVELINE CONTACT CAN CAUSE DEATH

KEEP AWAY!

DO NOT OPERATE WITHOUT-

- ALL DRIVELINE GUARDS, TRACTOR AND EQUIPMENT SHIELDS IN PLACE
- DRIVELINES SECURELY ATTACHED AT BOTH ENDS
- DRIVELINE GUARDS THAT TURN FREELY ON DRIVELINE

USA

US4

DEC101213P

Specifications

Pumps

Positive displacement oil-backed diaphragm pump of varying size depending on sprayer specification. Output at 540 PTO rpm and maximum operating pressure as shown below.

Pump Model	Output l/min	Pressure Bar	psi	No.of Diaphragms
BP 60/20	58	20	290	2
BP 75/20	67	20	290	3
BP 125/20	117	20	290	3

Note Maximum operating speed 540 rpm.

Minimum operating speed 400 rpm.

These pumps have been designed and constructed solely to pump agricultural liquid chemicals, normally used for pest, weed and fungus control.

They must not be used to pump:

- Liquids with a density and viscosity greater than water.
- Chemical products if the compatibility with the materials of the pump is not known.
- Sea water or other salty concentrations.
- Water with a temperature above 40°C and less than 5°C.
- Any type of varnish.
- Solvents and thinners for any type of varnish.
- Any type of fuel or lubricant.
- Liquids containing granules or floating solid parts.
- Chlorine.
- For special liquids please contact Silvan service department.

Pump Identification

The following data is found on the pump name plate:

1. Pump Type
2. Maximum Delivery (at 0 Bar)
3. Delivery at Maximum Pressure
4. Maximum Pressure Permitted in Pump
5. Maximum RPM
6. Manufacturer's Serial No

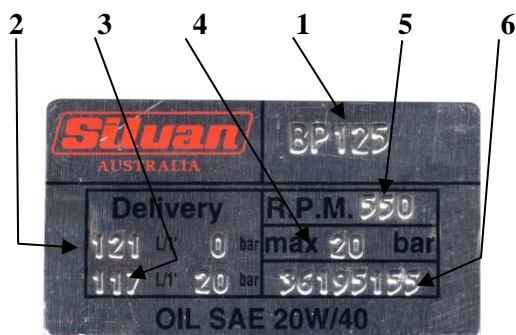

Component Identification

Refer to the following diagrams for the position of the various components relating to your pump.

1. Mounting Base
3. Pump Shaft
4. Oil Reservoir
5. Pressure Accumulator
6. Pump Head
7. Inlet Hose Barb
8. Inlet Valve Cap
9. Pump Crankcase
11. Inlet Manifold
12. Delivery Manifold
13. Oil Level Cap
15. PTO Safety Shield
16. Delivery Coupling
17. Oil Cap

BP60/20

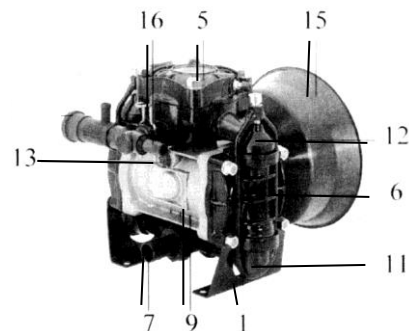

BP75/20

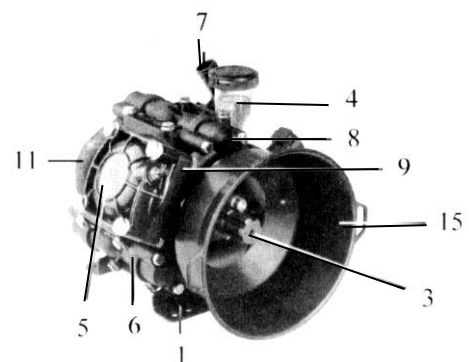

BP125/20

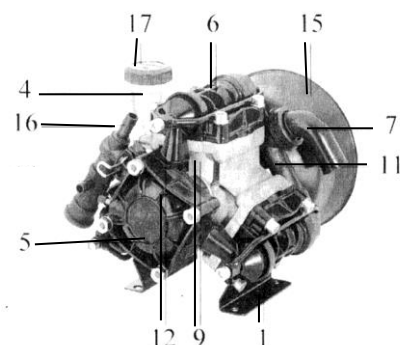

Specifications

Tank

Low-line designed tank constructed from Polytuff impact resistant polyethylene.
Capacity 400 / 600 / 800 / 1100 litres with calibrated external sightline.
255mm diameter screw down lid with basket strainer.
15 litre fresh water tank with on/off tap.
4 litre toolbox with easy access polyethylene lid.

Drive

540 rpm PTO shaft with safety shields.

Controls

Screw type pressure regulator.
Glycerin filled pressure gauge.
3 manual tap outlets.
Continuous bypass agitation.

Filtration

Three stage with removable elements on all units.
Standard mesh shown. Alternatives available.

- | | |
|--------------------------------|----------|
| 1) Tank lid strainer | 18 mesh. |
| 2) Suction line filter (blue). | 50 mesh |
| 3) Boom nozzle strainers | 50 mesh. |

Frame and Hitch

Heavy duty galvanized steel construction.
Reversible Category 1 & 2 linkage pins.

Factory or Dealer fitment options

Note: not all options will fit all models.

Flush tank 70 litre (600,800,1100 litre only)

Electric on/off 3 section controls

Automatic rate controller

Silmix chemical hopper

Hose Reels

Economy Hose Reel.

Spray Guns

PA Series or Triam Series.

Foam Marker

14 litre foam marker (single side)
16 litre foam marker (double side electric)
57 litre foam marker (double side electric)

Spray Booms

Field Boom 6m, 8m or 10m
Galvanized steel truss
Three section horizontal fold
Spring loaded break back

Fieldmaster Boom 12m

Manual cross fold
Suspension
Spring loaded break back

Devil Boom 6m, 8m, 10m, 12m, 14m, 15m

Galvanised steel truss
Hydraulic fold
Spring loaded break back
Hydraulic lift (optional)
Hydraulic lift with airbag suspension (optional)
Note: 12m, 14m & 15m Devil boom only available on 800 & 1100L sprayers (800L sprayers require heavy duty frame upgrade)

Vine Boom 8 or 10 Jet

Adjustable telescopic arms
Adjustable brass nozzles

Olive Boom 9 Jet

Adjustable sliding arm
Adjustable brass nozzles.

Under Vine Boom

Galvanised frame
Telescopic sliding adjustment for boom width and height
Double swivel nozzle holders can be fitted with standard fan or off centre nozzles.

Dimensions and Weights

Mass (kg) with a full tank and no boom fitted.

Sprayer without boom

	L(mm)	W(mm)	H(mm)	kg
400 Litre	930	1020	1180	505
600 Litre	1025	1150	1300	730
800 Litre	1350	1395	1315	980
1100 Litre	1350	1395	1610	1295

Width of Sprayer with boom folded for transport

<i>Field Boom</i>	6m	2.067m
	8m	2.067m
	10m	2.067m
<i>Devil Boom</i>	6m	2.120m
	8m	2.120m
	10m	2.120m
	12m	2.120m
	14m	2.120m
	15m	2.120m

Operation

Attaching to the Tractor

Silvan Super Series 400 litre linkage sprayers are equipped to fit tractors with either Category 1 or 2 linkages. The 600L, 800L & 1100L fit Cat 2 only. On the 400 litre the inner end of each lower linkage pin is Category 1 and the outer end is Category 2. The lower holes in the top connection plates are Category 1 and the upper holes are Category 2.

Remove the PTO shaft from the sprayer by depressing the locking pin. Lower the tractor linkage and attach it to the sprayer's lower hitch pins of the appropriate category, then connect the top link using the tractor's top link pin. Secure the linkage arms and top link pin with the tractor's lynch pins. Raise the tractor linkage to the desired spraying height and level the sprayer by adjusting the length of the top link and by using the lower arm levelling mechanism.

Clean and grease the splines on the tractor and sprayer PTO stub shafts and install the PTO shaft making sure that the spring-loaded locking pins engage in the interference grooves of both stub shafts. Ensure that the PTO shaft guard chains, if fitted, are attached to the sprayer and tractor.

PTO Shaft Length (Refer to instruction booklet INS42 attached to PTO shaft)

Note: Upon delivery of a new PTO driven sprayer, it is the selling dealer's responsibility to install and set the PTO driveshaft to the correct length, as part of the installation service. The following information is provided for reference.

Set the linkage height so that the ends of the two shafts are at their closest distance. Install the PTO shaft making sure that there is at least 25mm of telescopic travel remaining between the male and female sections. Raise and lower the sprayer to check that the telescopic tubes of the PTO overlap by approximately 1/3rd of their length, and not less than 150mm, in all operating positions.

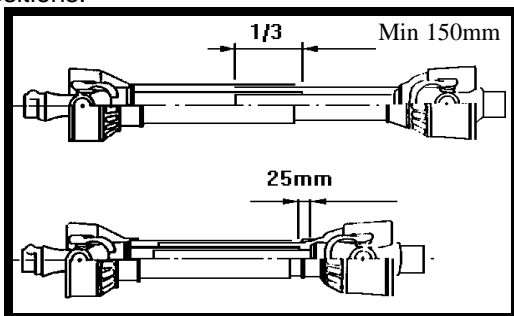

If the PTO shaft must be shortened, cut equal amounts from both male and female shafts and safety covers. Carefully remove all burrs then clean and lubricate before reassembling.

Pump

1. Check the oil level while the pump is standing still and sitting horizontally. The oil must reach the level indicated on the sight glass (BP75/20, BP125/20 fig 1) or be visible on the oil level plug (BP60/20 fig 2). Top up with SAE20W/40 oil if necessary.

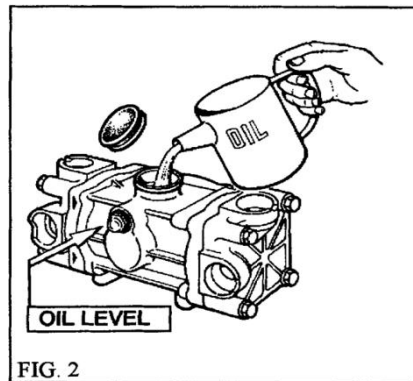
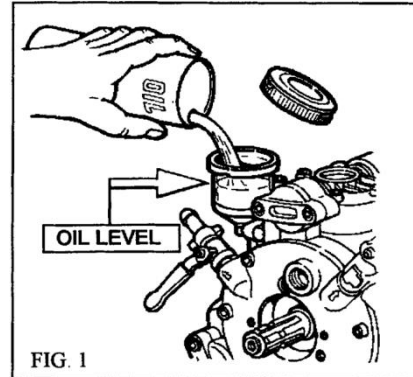

2. Adjust the air pressure in the pressure accumulator if fitted in accordance with the operating pressure used to spray. Adjust according to Table A. The pressure can be measured using a reliable bicycle fork pressure gauge. (Note a car tyre or bicycle tyre gauge lets too much air escape to be accurate).

Surge air pressure	Bar	2-5	5-10	10-20	20-50
Spraying pressure	Bar	2-5	5-10	10-20	20-50
	p.s.i.	29-73	73-145	145-290	290-725
Surge air pressure	Bar	2	2-5	5-7	7
	p.s.i.	29	29-73	73-102	102

Alternatively add air to the accumulator, to just above the required pressure (using a car tyre inflator is OK) start the pump and adjust the pressure regulator to the required pressure then bleed air from the accumulator until the pulsations of the pump are least noticeable, at this point the needle on the pressure gauge will be at its steadiest.

Operation



OPTIONAL FLUSH TANK

To Fill The Flush Tank:

1. Remove the cap (top left hand side of the Flush Tank)
2. Place hose in the tank opening
3. Fill the tank with water (70L)
4. Replace the cap after filling the tank.



To Flush The System:

1. After Spaying, Disengage the PTO.
2. Turn the ball valve from the “Main Tank” (12 o'clock) to the “Flush Tank” (6 o'clock) position
3. Turn the unit back on to flush the system (With the **Section Valves** turned **ON**).

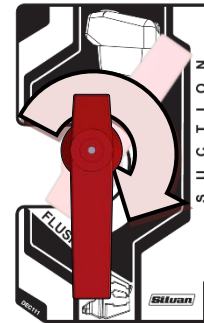
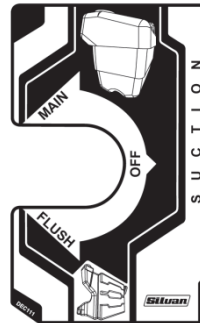

To Clean The Filter:

1. Disengage the PTO
2. Turn the ball valve to the “Off” position (3 o'clock)
3. Unscrew the Filter Nut & Remove the Filter Bowl
4. Clean the Filter
5. Secure the filter & Filter Bowl in position

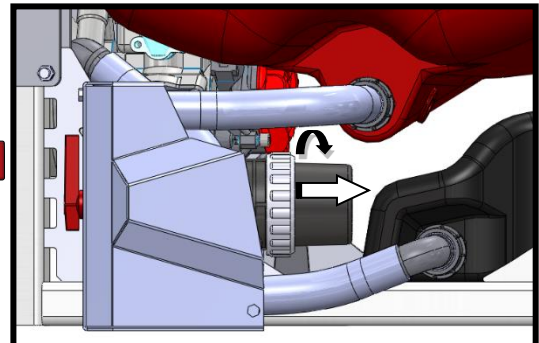
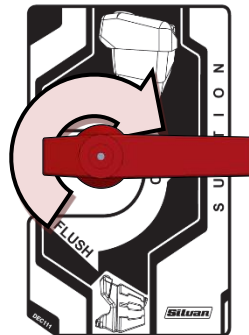

To Drain The Main Tank:

1. Disengage the PTO
2. Turn the ball valve to the “Off” position (3 o'clock)
3. Unscrew the Filter Nut & Remove the Filter Bowl
4. Turn the ball valve to the “Main Tank” position to drain the main tank

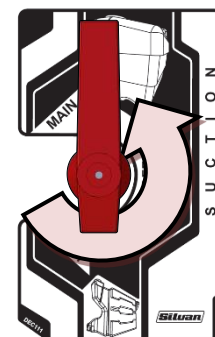
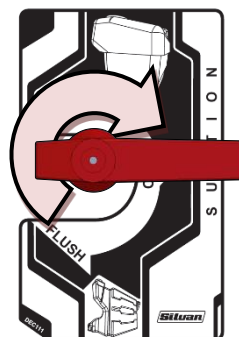

To Drain The Flush Tank:

1. Disengage the PTO
2. Walk around to the right hand side of the machine
3. Remove the end cap
4. Allow water to drain
5. Secure the cap back into place.

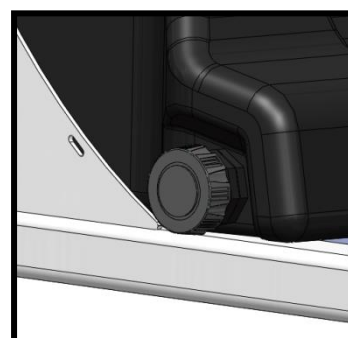

Operation

Filter

The suction filter is fitted with a stop valve which closes automatically when the valve cap is screwed off. This allows the filter cover to be unscrewed and the element to be removed for cleaning while there is fluid in the tank.

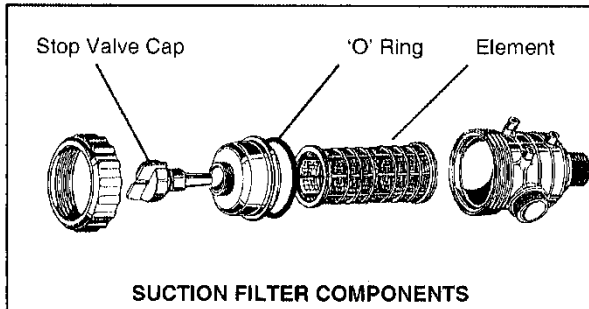

When the sprayer is operating, the valve must be fully screwed in to open the stop valve and allow fluid to pass through the filter. Directional arrows are moulded into the valve cap to show the opening and closing operation

Three Outlet Control Units

System pressure is regulated by turning the green knob and observing the reading on the pressure gauge. Turning the knob clockwise increases the pressure and turning anti-clockwise decreases pressure.

Fluid is directed to the boom lines or other spraying devices by the outlet valves which may be operated individually. The outlet valves of the three way control are open when the levers are vertically up and closed when they are horizontal. Refer to diagram.

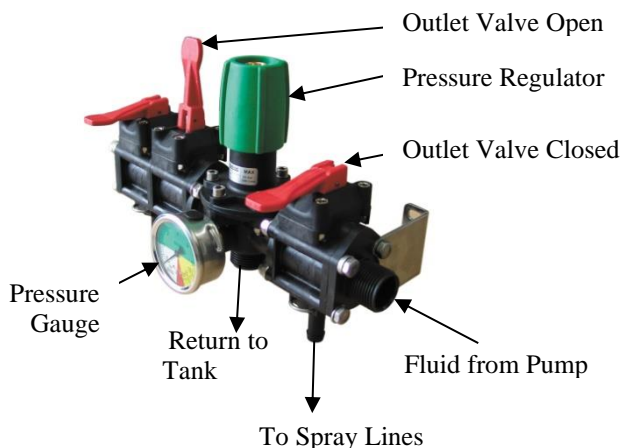

Fresh water tank

To fill the 15 fresh water tank, remove the lid and fill. Ensure that the lid of the fresh water tank is not swapped with the chemical fill lid (applicable only to the 400 & 600 litre models).

Turn the tap fitted to the side of the fresh water tank to the on position to wash hands.

Warning! The fresh water tank should only be filled with fresh water for hand washing or nozzle cleaning. This water should not be used for drinking purposes.

Toolbox

To open the toolbox, remove each of the tri-screws holding the lid secure. Ensure the tri-screws are secured firmly when closing the lid.

Spray Booms

A variety of booms may be used with Silvan linkage sprayers depending upon the model and field application. All have stainless steel spray lines fitted with non-drip nozzle bodies and air induction fan jet nozzles. Booms are part of the standard equipment on some models or in other cases they may be installed by the dealer.

On all types of boom, the setting of the correct operating height is most important to achieve a uniform spraying pattern. This needs to be at a height above the target which will achieve 50% overlap of the spray from adjacent nozzles - refer Calibration section of this manual.

Always ensure that no bystanders are close to the boom when it is unfolded and that it will not foul on any other objects.

Field Boom

For transport, the boom is folded horizontally by swinging the outer arms rearwards through 180° until against the fixed centre section, where they are retained by the action of the hinge springs. The arms are simply folded outwards to the spraying position when required.

The rear uprights of the sprayer frame include open slide channels to enable the boom to be attached at a height suitable for the tractor size and spraying application. Final spraying height is regulated by use of the tractor linkage control.

Devil Boom

The hydraulic fold Devil boom features independent left and right hydraulic folding arms for either one-side or two side operation. The outer arm fold utilises a push rod that is connected to the inner fold hydraulic ram. The outer arm has a spring loaded breakback mechanism. There is an optional hydraulic lift kit and optional hydraulic lift with airbag suspension available with the Devil booms.

Operation

Folding and Unfolding the Devil Boom



Always ensure that the boom is folded or unfolded in a safe area where it will not foul on any other objects. Look up before folding or unfolding to check for obstructions. Never fold or unfold near overhead power lines. Ensure that all bystanders are clear before moving the boom.

Unfolding: The boom will slide free from the saddles when unfolded. Use the tractor hydraulic lever to slowly unfold one arm at a time until the hydraulic cylinder is fully extended.

Folding: Fold the boom slowly, one arm at a time with the tractor hydraulics until the arm rests on the support saddle.

Devil Boom Setup

1. Unfold each arm using the tractor remotes.
2. When the hydraulic ram is fully extended, the bolt through the end of the ram must go the whole way to the end of the slot (below). Even a small gap will result in a whipping outer section.

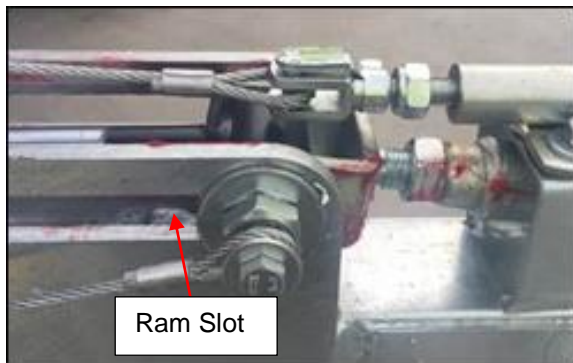

3. When the ram is at the end of the slot, the spring washers on the boom side of the bracket (right side below) must be fully compressed.

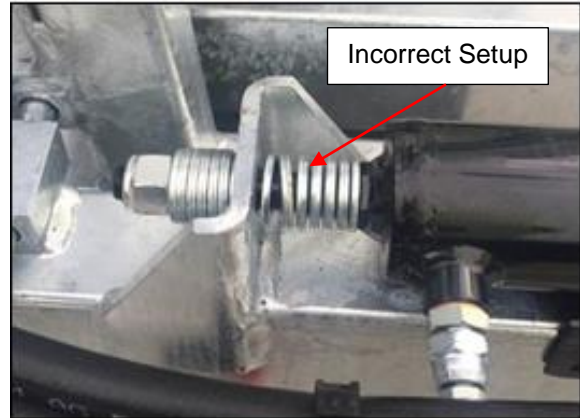
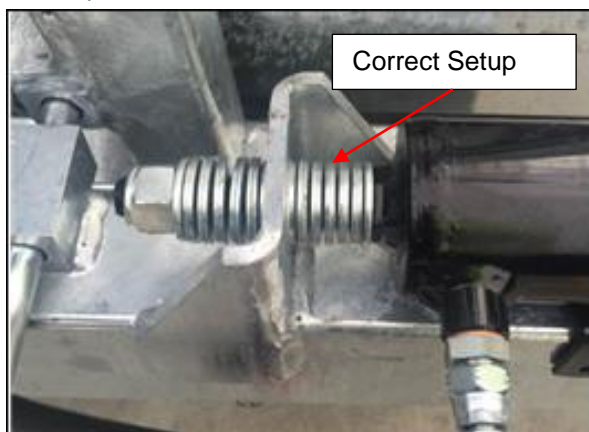

4. After the ram setup is complete, make sure the outer arm pushrod is extended out so it holds the outer section down when the ram is at full stroke (if the push rod is set too short, the outer section will whip).

Foam Marker

Refer to the Foam Marker Operator's Manual for installation and operating procedures relevant to the foam marker.

Spray Guns and Hose Reels

To operate the spray gun prime the pump as per normal then open the relevant control lever, set to the desired pressure (max 20 Bar). Depress the trigger to spray.

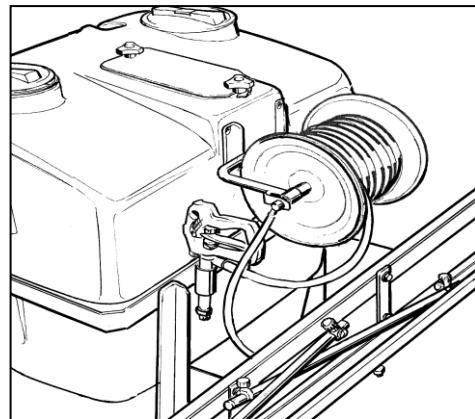

Filling the Main Tank using Bottom Connection (1100L only)

The main tank can be filled through either the top lid or bottom cam lock connection. The bottom cam lock is preferred as it stops the chemicals frothing. It is also safer as the tank can be filled from ground level. The bottom fill is protected from back flow by a non-return valve inside the tank.

Undo the catches and remove the cap from the bottom fill connection. Connect a filling hose with a 50mm cam lock coupling to the connection

then turn on the water supply. When filling is complete, shut off the supply, disconnect the hose, replace the bottom fill cap and close the catches.

Starting the Sprayer

Before starting the sprayer for the first time ensure the pre-delivery checks have been carried out.

When starting the sprayer for the first time, conduct a trial run using water to become familiar with the operation of the controls and to check that all systems are functioning correctly without any leakage.

When filling the tank, ensure that the basket strainer is in place and clean. Close the lid securely after filling.

Before engaging the PTO, the pressure regulator should be screwed fully out (anti clockwise) to allow by-pass to the tank and the outlet valves should be closed, using the individual valve levers (levers to be horizontal). (Repeat this procedure each time the pump has been emptied of liquid i.e. run dry.

Engage the PTO slowly and allow the sprayer to run in by-pass mode. Once the pump is primed, increase the PTO speed to 540 rpm.

The pressure can then be regulated by turning the regulator knob and observing the reading on the gauge.

The pumps are designed to operate up to a maximum pressure of 20 bar (290 psi). The pressure range used for boom spraying will usually be between 1 and 4 Bar depending upon the application rate and other factors - refer to the Calibration section of this manual.

Open the outlet valves that are connected to the boom or other spraying device to start spraying.

Under most boom spraying conditions, the PTO speed can be reduced (minimum 400 rpm) and the pump will still provide sufficient flow to suit the particular application rate being used. This will save fuel and unnecessary wear on the tractor and sprayer components.

Adding Chemicals with the Chemical Induction Probe (1100L only)



Before adding chemicals read and follow the chemical manufacturer's instructions and wear the recommended personal protective clothing.

Before adding any chemicals with the induction probe fill the tank with at least 250 litres of water. With the tractor PTO running at no less than 400 PTO rpm turn the outlet valves OFF and the chemical probe valve (located on control unit) ON.

Adjust the system pressure using the pressure regulator to a maximum of 10 Bar to operate chemical probe. Remove the chemical probe from the holder located behind the tank.

Insert the chemical induction probe into the chemical container and open the ball valve at the top of the probe to start drawing chemical into the main tank. Continue filling the main tank with water and keep the pump running to thoroughly mix the solution.

Shutdown

After using chemicals in the sprayer flush the tank and pump by running clean water for a few minutes. If there is a risk of freezing run the pump dry for 2 to 3 minutes to ensure all liquid is removed.

When to Spray

Results will be best when the wind speed is low; temperature is low and relative humidity high. An ideal time is at sun up when these conditions are most likely to apply.

Field Patterns

For overall coverage, spray two swaths around the outer perimeter of the field to establish a wide headland on which to turn. Make subsequent passes across the field following the direction of drilling. Turn the sprayer on and off as the boom passes over the headland. Spraying into the established headland will only result in chemical wastage and overdosing.

Droplet Size

Although more research is needed to define which is the optimum droplet size collected by particular targets, certain generalizations can be made. The trend with herbicides has been to apply large droplets (250 microns) to reduce the risk of drift but smaller droplets are often the most effective as shown by the following table.

DROPLET SIZE	COMMENTS
Large (above 300 microns)	Poor coverage and penetration. Stripping or uneven deposit. Minimal drift
Medium (150 - 300 microns)	Coverage, deposit and penetration fair. Some drift.
Small (below 150 microns)	Good coverage and penetration. Uniform application. Drift increased.

Silvan has a range of standard flat fan nozzles designed for a normal operating pressure of 3.0 bar. If using products containing 2,4-D there are specific label conditions relating to the size of spray droplets that must be applied to minimize drift potential.

In general, the following factors can be varied to change droplet size.

- Reducing pressure increases droplet size.
- Reducing the nozzle fan angle (from 110° to 80°) increases droplet size.
- For an equivalent pressure and fan angle a larger size jet produces larger droplets.

Nozzle Height and Spacing

To achieve a uniform spray pattern without gaps, the output from adjacent nozzles should overlap by 50% at the point of contact with the surface being sprayed.

Nozzles on Silvan booms are spaced at 50 cm intervals with caps offset 5° to the boom axis to

avoid interference between adjacent spray fans. They can be supplied in 110° or 80° fan angle.

The correct spray boom height to achieve 50% overlap is 40 cm for 110° nozzles and 60 cm for 80° but a variation in the order of 5 to 8 cm can be accommodated without noticeable effect. The height referred to is the distance above the target which may be either the vegetation or the ground surface depending upon the operation.

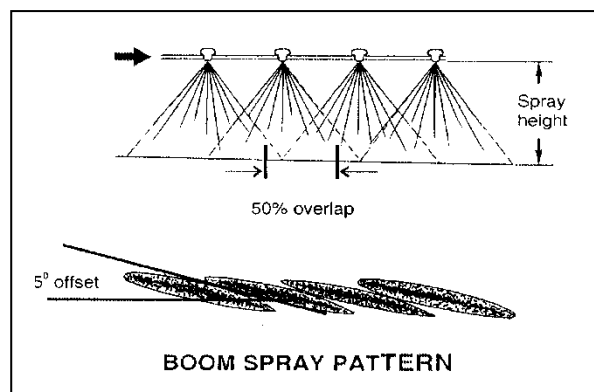

Application Rate

The application rate depends on the following:

- Speed of travel - increasing speed reduces application rate and vice versa.
- Operating pressure - increasing pressure increases application rate and vice versa.
- Nozzle size - increasing the nozzle size increases the application rate.

Ground Speed

The ground speed read out on modern tractors should be sufficiently accurate for spraying but if in doubt check it by the following method.

Measure and mark a distance of 100 metres. Fill the sprayer with water and engage the PTO to simulate normal spraying conditions. Approach the starting mark at the required spraying speed and accurately measure the time in seconds to reach the finishing mark. The ground speed can be calculated as follows.

$$\text{Speed (km/hr)} = \frac{360}{\text{Time in seconds for 100 m}}$$

Calibration

Spray Pattern and Nozzle Uniformity

The overlap pattern of the boom, the spray pattern of individual nozzles and the uniformity of nozzle output can be tested in the following manner. Always keep one new nozzle aside from each set to use as comparator for this test.

1. Install the comparator nozzle, fill the sprayer tank with clean water and operate the boom at spraying pressure whilst stationary.
2. Examine the spray pattern from each nozzle against a dark background. Replace any that show streaks or signs of blockage.
3. Compare individual nozzle outputs by placing a container of equal size, such as the Silvan calibrated measuring jug, under each nozzle and run the sprayer for one minute. The water level in each container should be the same. Replace any nozzle giving more than 10% greater output than the comparator. Once several nozzles are worn to this extent it is good practice to replace the entire set.
4. Set the boom at the appropriate height for the nozzle angle, i.e. 60 cm for 80° and 40 cm for 110°. Run the sprayer and check that the patterns from adjacent nozzles just meet as shown in the diagram on the previous page.
5. Remove and store the comparator nozzle.

Verifying the Calibration

After making the above tests to ensure pattern and output uniformity are correct, repeat the procedure at 3.0 Bar to compare the actual nozzle output with that shown on the nozzle selection charts. This may be done either as a test on an individual nozzle or the full boom.

a) Nozzle Test

Measure the fluid in litres, collected from one nozzle during one minute. The amount should agree with the flow rate shown in the Nozzle Selection Chart on the following pages, for the particular type and size fitted.

If the volume collected is too low the operating pressure may be increased and the test repeated, alternatively if the volume is too high the pressure can be lowered.

b) Boom Test

1. Partly fill the sprayer tank with water and mark the level or refer to the sight gauge.
2. Run the sprayer at 3.0 Bar for several minutes with all boom sections operating and measure the time carefully.
3. Refill the sprayer tank to the mark using a measuring jug and record the amount added.

4. The average output for one nozzle in l/min can be calculated as follows. It should agree with the flow rate shown at 3.0 Bar in the nozzle selection chart, for the particular type and size fitted.

$$\text{Nozzle output} = \frac{\text{Litres used}}{\text{No. nozzles} \times \text{No. minutes}}$$

5. If the nozzle output is lower than shown in the chart the pressure may be increased and the test repeated or, if more than shown, the pressure may be reduced.

Nozzle Care and Maintenance

Nozzles are one of the most critical components in the spraying system and yet are often the most neglected. Worn or damaged nozzles result in over application of expensive chemicals, crop damage and environmental contamination.

They should be examined and checked regularly by the method shown above. Replace nozzles which are not within 10% of the datum.

Always keep a quantity of spare nozzles with the sprayer for immediate replacement in the field when necessary.

Never attempt to clear a nozzle by blowing through by mouth and never remove stubborn deposits with a pin, wire or sharp instrument.

Blocked nozzles should be soaked in clean, warm water with a mild detergent added and carefully cleaned only with a soft brush or airline.

A new nozzle should be kept as a testing comparator and it is recommended that all nozzles are renewed once a year or at the first signs of deterioration, whichever occurs first.

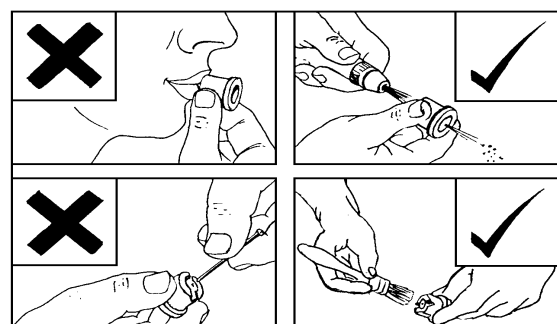

Nozzle Selection

Refer to the chemical manufacturer's information to determine the recommended application rate in litres per hectare (l/ha) for your particular situation. Then determine the speed in kilometres per hour (kmh) at which you intend to spray, taking into consideration the ground conditions of the area to be sprayed.

Using the appropriate chart for your boom, select the most suitable nozzle to use at the normal recommended pressure of 3.0 Bar. The leading digits in the nozzle number indicate whether it is an 80° or 110° fan angle and the last two digits

refer to the size of the opening. Nozzles are ISO colour coded for easy identification.

All Silvan booms are fitted with air induction nozzles suitable for a pressure range from 1.5 to 6.0 Bar. The chart below applies to ISO colour code nozzles.

For sprayers fitted with a Vineyard boom refer to the calibrating chart supplied with the boom. If necessary obtain this information from your Silvan dealer.

An example of how to use the calibration chart is shown below.

SILVAN SPRAYER CALIBRATION CHART

1 BAR = 14.5 PSI NOZZLE SPACING = 50cm
ISO STANDARD NOZZLE OUTPUT CHART FOR 80°/110° NOZZLES

ISO COLOUR CODE	LIQUID PRESSURE (BAR)	FLOW RATE L/MIN.	APPLICATION RATE: LITRES PER HECTARE																							
			6	8	10	12	14	16	18	20	22	24	26	28	30											
FAN TIP ORANGE 80-01 100 MESH	2.0	0.33	65	49	39	33	28	24	22	20	18	16	14	13	12	11	10	9	8	7	6	5	4	3	2	
	2.5	0.37	73	55	44	37	31	27	24	22	20	18	17	16	15	14	13	12	11	10	9	8	7	6	5	
	3.0	0.40	80	60	48	40	34	30	27	24	22	20	18	17	16	15	14	13	12	11	10	9	8	7	6	5
FAN TIP GREEN 80-015 100 MESH	2.0	0.45	92	69	55	46	39	35	31	28	25	23	21	20	18	17	16	15	14	13	12	11	10	9	8	7
	2.5	0.49	98	74	59	49	42	37	33	29	27	25	23	21	20	19	18	17	16	15	14	13	12	11	10	9
	3.0	0.50	110	82	66	55	47	41	37	33	30	27	25	23	22	21	20	19	18	17	16	15	14	13	12	11
FAN TIP YELLOW 80-02 50 MESH	2.0	0.69	139	104	83	69	59	52	46	42	38	35	32	30	28	26	24	22	20	18	17	16	15	14	13	12
	2.5	0.73	146	110	88	73	63	55	49	44	40	37	34	31	29	27	25	23	21	19	18	17	16	15	14	13
	3.0	0.80	160	120	96	80	69	60	53	48	44	40	37	34	32	30	28	26	24	22	20	18	17	16	15	14
FAN TIP BLUE 80-03 110-03 80 MESH	2.0	0.82	185	139	111	92	79	69	62	55	50	46	43	40	37	35	33	30	28	26	24	22	20	18	17	16
	2.5	0.98	196	147	118	98	84	74	65	59	53	49	45	42	39	37	35	32	30	28	26	24	22	20	18	17
	3.0	1.10	219	164	131	110	94	82	73	66	60	55	51	47	44	42	40	37	35	32	30	28	26	24	22	21
FAN TIP RED 80-04 110-04 50 MESH	2.0	1.20	240	180	144	120	103	90	80	72	65	60	55	51	48	46	44	40	38	36	34	32	30	28	26	24
	2.5	1.20	259	194	156	130	111	97	86	78	71	65	60	56	52	50	48	44	42	40	38	36	34	32	30	28
	3.0	1.28	277	208	166	139	119	104	92	83	75	69	64	59	55	53	51	47	45	43	41	39	37	35	33	31
FAN TIP BROWN 80-05 110-05 80 MESH	2.0	1.31	261	196	157	131	112	98	87	78	71	65	60	56	52	50	48	44	42	40	38	36	34	32	30	28
	2.5	1.46	282	219	175	146	125	110	97	88	80	73	67	63	58	56	54	50	48	46	44	42	40	38	36	34
	3.0	1.80	320	240	192	160	137	120	107	95	87	80	74	69	64	62	60	56	54	52	50	48	46	44	42	40
FAN TIP GREY 80-06 110-06 50 MESH	2.0	1.73	346	259	207	173	148	130	115	104	94	86	80	74	69	67	65	61	59	57	55	53	51	49	47	45
	2.5	1.85	368	277	222	185	158	139	123	111	101	92	85	79	74	72	70	66	64	62	60	58	56	54	52	50
	3.0	1.96	382	294	235	196	168	147	131	118	107	98	90	84	78	76	74	70	68	66	64	62	60	58	56	54
FAN TIP WHITE 80-07 110-07 80 MESH	2.0	2.19	438	329	263	219	188	164	146	131	120	110	101	94	88	86	84	80	78	76	74	72	70	68	66	64
	2.5	2.40	480	360	288	240	206	180	160	144	131	120	111	103	96	94	92	88	86	84	82	80	78	76	74	72
	3.0	2.68	518	388	311	259	222	194	173	156	141	130	120	111	104	102	100	96	94	92	90	88	86	84	82	80

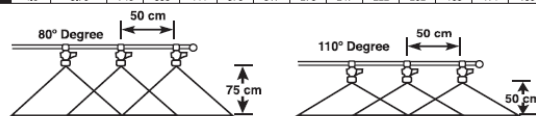

CAUTION: ALWAYS MANUALLY CALIBRATE THE SPRAYER TO VERIFY APPLICATION RATE
ALWAYS REFER TO CHEMICAL LABEL FOR DROPLET SIZE REGULATIONS

Using the Calibration Charts

For example, a rate of 96 l/ha can be achieved at a ground speed of 10 kmh using 3.0 Bar pressure with a 110-02 yellow nozzle - refer to the nozzle selection chart on the previous page.

If the exact application rate does not appear in the chart it can be achieved by slightly adjusting the speed or pressure. For example, if a rate of 100 l/ha is required rather than 96 l/ha, it can be achieved with the same yellow nozzles by reducing the speed to 9.5 kmh or increasing pressure to approximately 3.2 Bar.

Alternatively, the same rate of 100 l/ha could also be achieved with a larger nozzle and faster operating speed. By referring to the nozzle chart on the previous page it can be seen that a 110-03 blue nozzle will give this rate at a little under 14 kmh and 3.0 Bar (the rate shown on the chart at 14 kmh is 103 l/ha).

It can thus be seen that a variety of choices exist for most application rates and the final selection of nozzle, speed and pressure will depend upon the factors which best suit your conditions.

Always perform a calibration check to confirm your nozzle selection, as described on page 14.

Maintenance

Before performing any maintenance

Disconnect the tractor PTO and ensure the sprayer is adequately supported before performing any operation on the sprayer.

AFTER EVERY TANK

Pump Oil Condition

The condition of the pump oil should be frequently checked (eg. each time the tank is filled) as it effects the operation of the pump and the condition and life of the diaphragms. If the oil becomes white (water present in oil), it may be a symptom of failure of one or more diaphragms. It is necessary to **stop work** and inspect the condition of the diaphragms. If broken, it is necessary to replace the complete set.

Continued use with water in the oil will cause serious damage to internal parts of the pump.

If it is not possible to replace broken diaphragms within one day of failure, empty the crankcase of water and pour in oil to stop rust from forming on the internal components.

Oil Level

When the pump is stationary, the oil level must correspond to the reference indicator found on the oil sight glass (fig 2) or oil level cap (fig 1) depending on the type of pump (see Operations section page 9). The oil level may vary when the diaphragm pump is working: As the pump is started, the oil level will initially drop and then return to functioning level when the liquid begins to pump.

During operation, pay attention to any drop in the oil level:

- If this happens during the first few hours of operation it is normal and it is sufficient to top up with SAE 20W/40 type oil.
- If this happens after many hours of operation and continues after 1 or 2 top ups, it is a symptom of diaphragm swelling caused by restricted suction (dirty filter, collapsed suction hose or chemical attack to diaphragm). In this case check the filter and suction system and/or refer to your Silvan dealer to check the diaphragm.

Filters

Always clean the suction filter before each tank refill (especially if powder based products are used) and at the end of the day. Close the stop valve by pushing the cap in and turning it in the direction indicated on the cap nut, then unscrew the filter cover to remove the filter element - refer diagram in Operation section. Ensure the 'O' ring is in good condition when refitting.

Reassemble in reverse order.

Check and if necessary clean the basket strainer under the tank lid before each fill.

DAILY MAINTENANCE

General

During the first few days of operation, before starting each day check that all hardware is tight and inspect the unit for leaks while running and tighten all hose clamps.

PTO Shaft

For safety considerations, it is **very important** to inspect the condition of the PTO guard and chains daily and to maintain as necessary.

Grease the PTO shaft and guard with multi-purpose grease at the time intervals shown below. This is the amount of lubrication recommended for normal operation. More frequent inspection and lubrication may be needed under very dusty conditions.

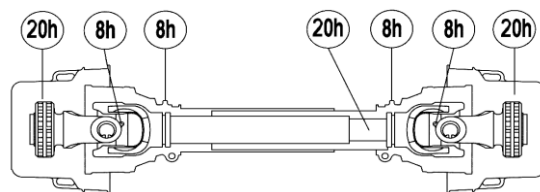

Remove the shaft from the tractor and sprayer, slide the PTO shaft apart, clean the telescopic tubes and female ends with kerosene and apply multi-purpose grease to the sliding surfaces, then reassemble. This is most important in dusty conditions.

Maintenance

Filters

Clean all filters daily. More frequent cleaning may be found necessary depending upon circumstances. The best method for cleaning filters is to wash them with a soft bristle brush. Check for any tears or holes and replace if damaged.

Pump Mounting

Check daily, especially when there is vibration during use that the pump mounting bolts on the machine frame are tight and if necessary re-tighten.

Tank and Spray Lines

At the end of each day run clean water through the pump and lines to purge them of chemicals. Rinse out the tank to remove powdered material.

Never leave chemicals in the tank that may settle to the bottom, harden and break into lumps as this may block the suction filter.

Freezing Conditions

If frosts or freezing conditions are likely to occur then drain all water from the pump to ensure the pump is not damaged by freezing water expanding inside the pump.

EVERY 50 HOURS

Diaphragm Pump

Check the inflation of the pressure accumulator, if fitted, according to Table A (in the Operations section of this manual) especially if there are vibrations on the delivery hose and/or the pressure gauge.

Pressure Regulator

Grease rotating and sliding parts.

Plumbing

The suction system must be inspected to ensure:

1. There are no suction air leaks. Check for entry of air caused by:
 - entry of air caused by hose wear;
 - loose fittings;
 - worn joints;
2. There are no small leaks or drips on the suction side of the pump when it is stationary. If this occurs it means air will enter the pump when in operation.
3. There are no leaks around all hoses and fittings.

Hardware

Check all bolts are tight. Refer to Silvan Torque setting chart available from Silvan Technical Support Dept.

EVERY 300 HOURS

Diaphragm Pump

Every 300 hours (or more often if sandy water or abrasive liquids are used) change the oil and the diaphragms in the pump and inspect the mechanical condition of the components. This must be carried out by an authorized Silvan dealer.

Pressure Regulator

Check the pressure adjustment valve.

PTO Shaft and Guard

Check the shaft and guard for wear and if necessary have it repaired by an authorized Silvan Dealer.

ANNUALLY

Diaphragm Pump

Check diaphragms and replace if necessary.
Replace the oil.

Pressure Regulator

Check and replace the inner diaphragm where required and check screws are tight.

Hardware

At the end of each season, generally inspect the sprayer for any signs of damage and check that all bolts are securely tightened.

Storage in cold areas

The pump is not frost proof therefore it is recommended that motor grade anti-freeze (diluted to the recommended proportions) be pumped through the system for 2 minutes. The system should then be drained by operating the pump for a further 2 minutes without taking up any liquid.

Trouble Shooting

TROUBLE SHOOTING

Pump does not prime

- No liquid in tank or not covering suction inlet.
- Suction filter blocked.
- Suction filter stop valve closed.
- Suction filter bowl loose or missing O-ring.
- Suction line loose allowing pump to suck air.
- Pressure regulator too tight to allow bypass.
- Pump valve springs broken or valves worn.

Pump does not reach correct pressure

- Pump not operating at full 540 rpm.
- Suction filter blocked.
- Suction filter stop valve partly closed
- Pressure regulator not correctly adjusted
- Pressure regulator valve and seats worn.
- Pressure gauge faulty
- Pump diaphragms ruptured (pump oil grey or milky).
- Worn nozzles or capacity of nozzles greater than capacity of the pump.
- Worn pump inlet / outlet valves

Pump and hoses vibrating.

- Pump surge chamber pressure incorrectly adjusted or surge diaphragm ruptured.
- Air entering the suction line through loose or damaged fittings.
- Pump valves or valve springs worn or damaged.
- Worn nozzles or capacity of nozzles greater than capacity of the pump.
- Air trapped in filter or suction lines.

Water in oil (oil is a whitish grey colour)

- Broken diaphragms.

Pressure regulator valve vibrates

- Worn adjustment plate seat

Pressure regulator leaking water

- Loose screws
- Damaged diaphragm in regulator

SILVAN AUSTRALIA PTY. LTD.
ABN 48 099 851 144

AUSTRALIA (HEAD OFFICE)

68 Atlantic Drive
Keysborough
Victoria, 3173
Telephone: 1300 745 826
Fax: 1800 745 826

www.silvan.com.au

NEW ZEALAND

22 Sunshine Ave
Te Rapa
Hamilton, 3241
Telephone: 0508 745 826
Fax: (07) 849 6070

www.silvannz.co.nz

